









More Precision

capa**NCDT** // Capacitive sensors for displacement, distance & gap



Compact capacitive measuring system for industrial use (single-channel) **capaNCDT 6100**

-  Compact and robust design
-  High resolution and accuracy in industrial applications
-  **INTER FACE** Analog output (current/voltage) and digital RS485 interface
-  **20kHz** Frequency response up to 20 kHz
-  Large range of models for versatile use
-  **made for OEM** Ideal for OEM applications



The capaNCDT 6100 is an analog, single-channel capacitive system that stands out for its robust design and high performance. Its compact design and ease of integration make it particularly well suited for integration into machinery and systems. The controller offers excellent value for money, particularly for OEM and series production.

This high-performance compact system is available in various models, making it suitable for a wide range of applications. Depending on the application, the focus may be on high speed, digital interfaces, exceptional durability, or long signal transmission paths, for example.

Robust, powerful and versatile – the capaNCDT 6100 controller

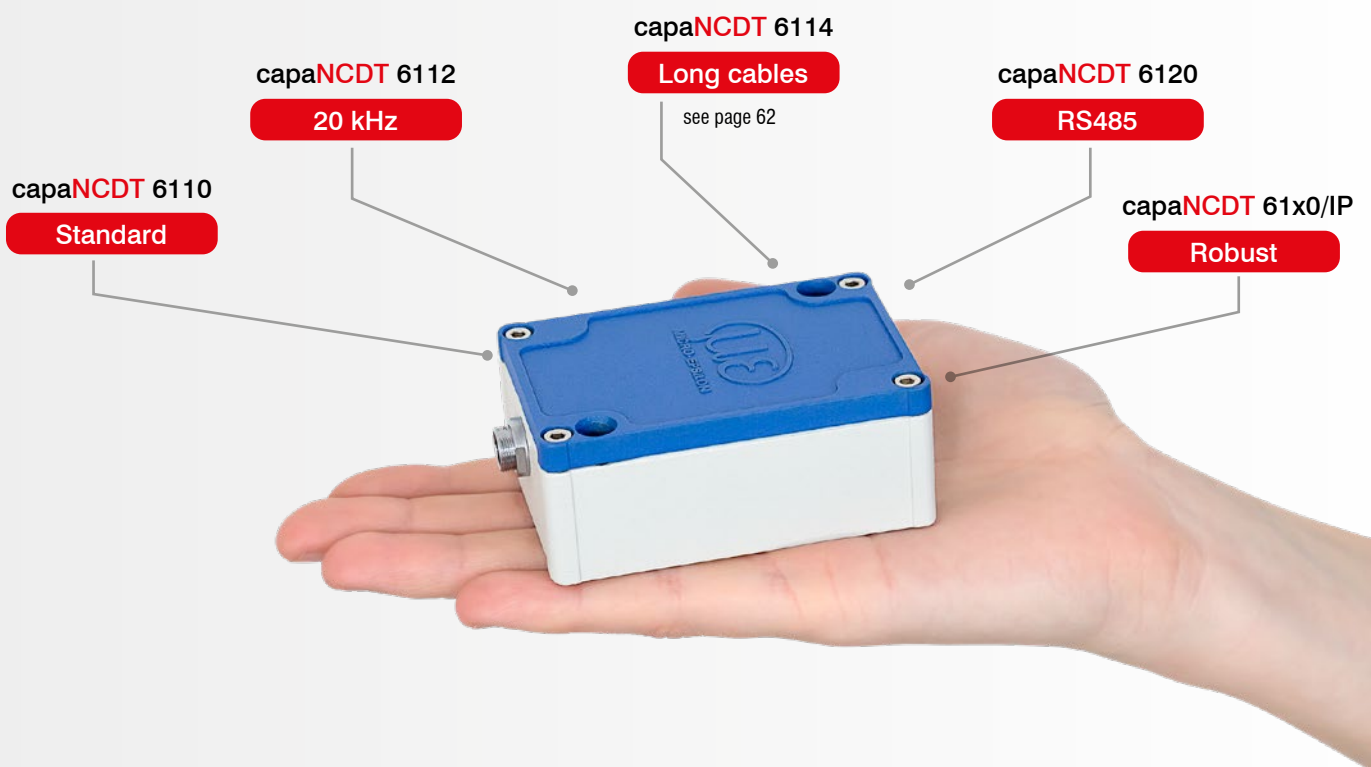

Model		DT6110	DT6112	DT6120	DT6110/IP	DT6120/IP
Resolution ^[1]	Static	0.0007 % FSO	0.0014 % FSO	0.0007 % FSO	0.0009 % FSO	
	Dynamic	0.015 % FSO	0.03 % FSO	0.015 % FSO	0.02 % FSO	
Frequency response (-3dB)		1 kHz	20 kHz	1 kHz	1 kHz	
Measuring rate		-	-	Selectable: max. 2 kSa/s	-	Selectable: max. 2 kSa/s
Linearity ^[2]		< ±0.05% FSO	< ±0.1% FSO	< ±0.05% FSO	< ±0.1% FSO	
Temperature stability		< 200 ppm FSO/K			< 50 ppm FSO/K ^[3]	
Replacement accuracy ^[4]		< ±0.1% FSO				
Long-term stability		< ±0.05% FSO/month			< ±0.02% FSO/month	
Synchronization		no				
Supply voltage		9 ... 36 VDC		9 ... 28 VDC	9 ... 28 VDC	
Power consumption		1.32 W (24 VDC)		1.44 W (24 VDC)	1.4 W (voltage) / 2 W (current)	1.6 W (voltage) / 2.2 W (current)
Digital interface ^[5]		-		RS485	-	RS485
Analog output		0 ... 10 V, optional: ±5 V, 10 ... 0 V			0 ... 10 V / ±5 V (short circuit proof) or 4 ... 20 mA (max. burden 500 Ω)	
Connection	Sensor	Pluggable cable via triaxial socket (type B)				
	Supply/ signal	5-pin connector (suitable connection cables, see accessories)		6-pin connector (suitable connection cables, see accessories)		
Mounting		2 x through-bores for M4 screw				
Temperature range	Storage	-10 ... 75 °C			-20 ... 75 °C	
	Operation	10 ... 60 °C			-20 ... 60 °C	
Shock (DIN EN 60068-2-29)		20 g / 5 ms in 3 axes, two directions each, 1000 shocks each				
Vibration (DIN EN 60068-2-6)		1 mm / 10 Hz ... 49.8 Hz in 3 axes, 10 cycles each 10 g / 49.8 ... 2000 Hz in 3 axes, 10 cycles each			2 mm / 10 Hz ... 35 Hz in 3 axes, 10 cycles each 10 g / 35 ... 2000 Hz in 3 axes, 10 cycles each	
Protection class (DIN EN 60529)		IP40			IP68	
Material		die-cast aluminum				
Weight		approx. 190 g				
Compatibility		compatible with all capaNCDT sensors				
No. of measurement channels		1				

^[1] FSO = Full Scale Output | RMS noise referred to the end of the measuring range; static = 2 Hz, dynamic = maximum frequency response of the controller

^[2] Applies to the controller only. The total linearity of the measuring channel is the sum of the controller and sensor values.

^[3] Valid at +10 °C ... +40 °C; 100 ppm FSO / K at -20 °C ... +10 °C and at +40 °C ... +60 °C

^[4] FSO = Full Scale Output | The value corresponds to the slope error that occurs when a sensor is replaced without recalibration

^[5] Baud rate 230400 Bd (adjustable), max. 2 kSa/s (adjustable), 24-bit measurement values

DT6110 / DT6112

Pin assignment for power supply and signal

Pin	Assignment	Color (color SCACx/5)
1	Supply +24 V	White
2	GND supply	Gray
3	Not assigned	Yellow
4	GND analog output	Green
5	Analog output V (load min. 10 kΩ)	Brown

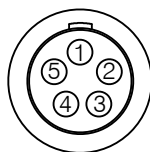

Solder side view,
5-pin socket

DT6120

Pin assignment for power supply and signal

Pin	Assignment	Color (color SCACx/6)
1	Supply +24 V	White
2	GND supply	Gray
3	RS485 A	Pink
4	GND analog output	Green
5	Analog output V (load min. 10 kΩ)	Brown
6	RS485 B	Blue

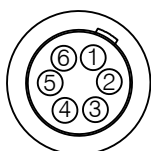

Solder side view,
6-pin socket

DT6110/IP and DT6120/IP

Pin assignment for power supply and signal

Pin	Assignment	Color (cable SCACx/6/IP)
1	Supply +24 V	White
2	GND supply	Gray
3	RS485 A	Pink
4	GND analog output	Green
5	Voltage output (load, min. 10 kΩ) Current output (max. 500 kΩ burden)	Brown
6	RS485 B	Blue

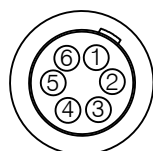

Solder side view,
6-pin socket

Controller dimensions

capaNCDT

DT6110, DT6112, DT6120

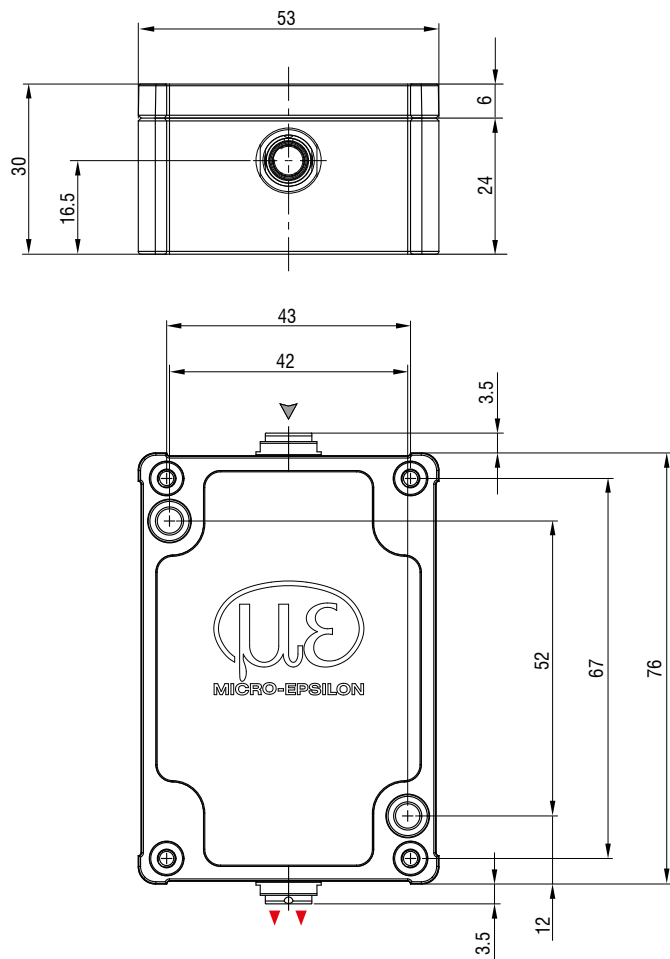

DT6110/IP, DT6120/IP

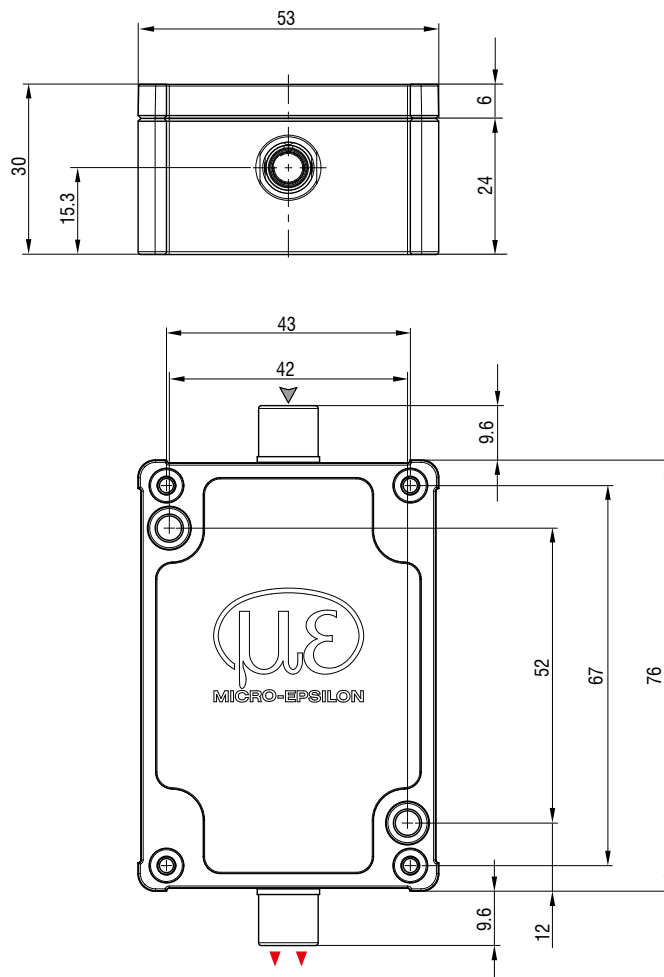

DT62xx

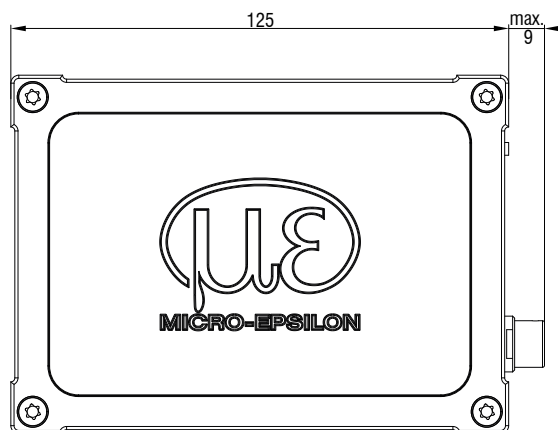
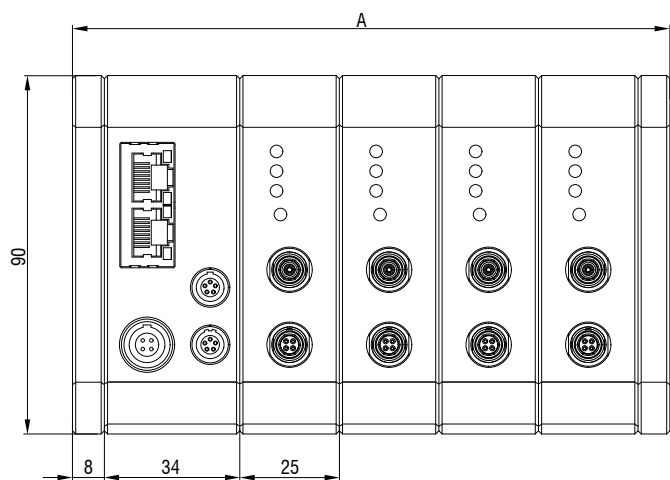

No. of channels	A (mm)
1	75
2	100
3	125
4	150

Connections and combinations

capaNCDT

Controller



DT6100



DT6200



DT6500

Sensor cable



Type: CCg

Robust triaxial cable for industrial applications
 Cable diameter: 3.1 mm (± 0.1 mm)
 Minimum bending radius: static approx. 10 mm /
 dynamic approx. 30 mm
 Temperature resistance: -20 ... +85 °C (permanent) /
 -20 ... +100 °C (limited to 10,000 h)
 Standard length: 2 m (optional lengths see p. 41)

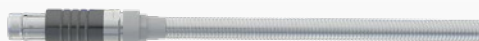

Type CCg/PT

Crush-resistant triaxial cable with protective metal tubing
 Cable diameter: 6 mm (± 0.15 mm)
 Minimum bending radius: static approx. 20 mm /
 dynamic approx. 30 mm
 Temperature resistance: -20 °C ... +85 °C (permanent) /
 -20 ... +100 °C (limited to 10,000 h)
 Standard length: 2 m (optional lengths see p. 41)

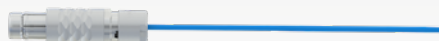

Type CCm

Low-outgassing triaxial cable for UHV and cleanroom
 Cable diameter: 2.1 mm (± 0.1 mm)
 Minimum bending radius: static approx. 7 mm /
 dynamic approx. 25 mm
 Temperature resistance: up to -100 ... 200 °C
 Standard length: 1.4 m (optional lengths see p. 41)



Type CCo

Low-outgassing triaxial cable for high temperatures
 Cable diameter: 3.1 mm (± 0.1 mm)
 Minimum bending radius: static approx. 10 mm /
 dynamic approx. 30 mm
 Temperature resistance: -20 ... +200 °C
 Standard length: 2 m (optional lengths see p. 41)

Sensors with integrated cable use the cable types CCM and CCg

Type CCM

Low-outgassing triaxial cable for UHV and cleanroom
 Cable diameter: 2.1 mm (± 0.1 mm)
 Minimum bending radius: static approx. 15 mm /
 dynamic approx. 30 mm
 Temperature resistance: up to 200 °C
 Standard length: 1.4 m (optional lengths see p. 41)

Type CCg

Robust triaxial cable for industrial applications
 Cable diameter: 3.1 mm (± 0.1 mm)
 Minimum bending radius: static approx. 10 mm /
 dynamic approx. 30 mm
 Temperature resistance: -20 °C ... +85 °C (permanent) /
 -20 ... +100 °C (limited to 10,000 h)
 Standard length: 2 m (optional lengths see p. 41)

Plug connector



Type B connector



Type B / 90 connector



Type B / IP connector



Type C connector



Type C / 90 connector



Type E connector

Sensors with socket



CS-x, CSE and CSE/Mx models
with a measuring range from 1 mm

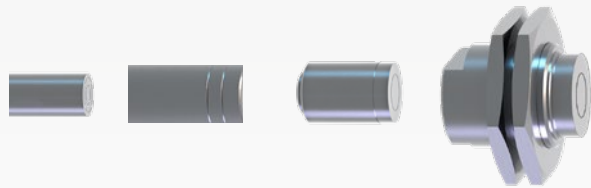

CS, CS-x, CSE and CSE/Mx models
with measuring range up to 1 mm



CSF flat sensors with socket

Sensors with integrated cable



Connection accessories and signal cables

capa**NCDT**

Controller accessories								
Article		Description	DT65xx	DT62xx	DT611x	DT6120	DT61x0/IP	
SCACx/4		Analog signal cable 4-pin with XYZ connector / open ends Standard length: 3 m Optional lengths available: 6 m / 10 m / 12 m / 15 m		X				
PC6200-x/4		Power supply and trigger cable 4-pin with XYZ connector / open ends Standard length: 3 m Optional lengths available: 5 m / 15 m		X				
SC6000-x		Power supply and trigger cable 5-pin with XYZ connector / open ends Standard length: 0.3 m Optional lengths available: 3 m / 5 m / 15 m	X	X				
SCACx/5		Power supply and signal cable 5-pin with XYZ connector / open ends Standard length: 3 m Optional lengths available: 4 m / 5 m / 6 m / 8 m / 15 m			X			
SCACx/6		Power supply and signal cable 6-pin with XYZ connector / open ends Standard length: 3 m				X		
SCACx/6/IP		Power supply and signal cable IP68 6-pin with XYZ connector / open ends Standard length: 3 m					X	
CAx		Pre-amplifier connection cable 5-pin with XYZ connector both ends Standard length: 3 m Optional lengths available: 5 m / 10 m / 15 m / 20 m	X					
CMP6011		External preamplifier for standard measurements	X					
CP6001		External preamplifier for high precision measurements	X					
PS2020		Power supply unit Input 100-240 VAC Output 24 VDC / 2.5 A Mounting on a symmetrical DIN rail 35 mm x 7.5 mm DIN 50022		X	X	X	X	
IF1032		Interface module for Ethernet/EtherCAT			X	X	X	

CPM6011
External preamplifier

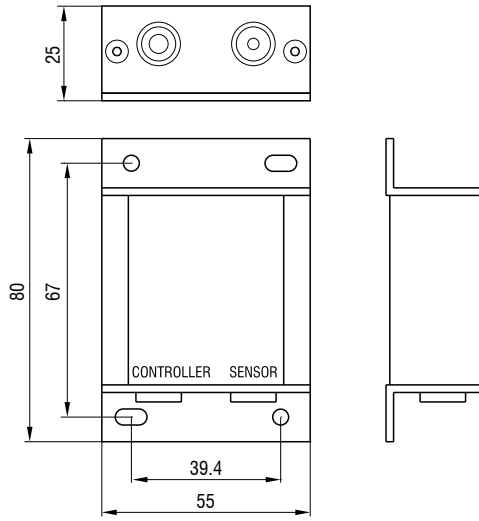

CP6001
External preamplifier

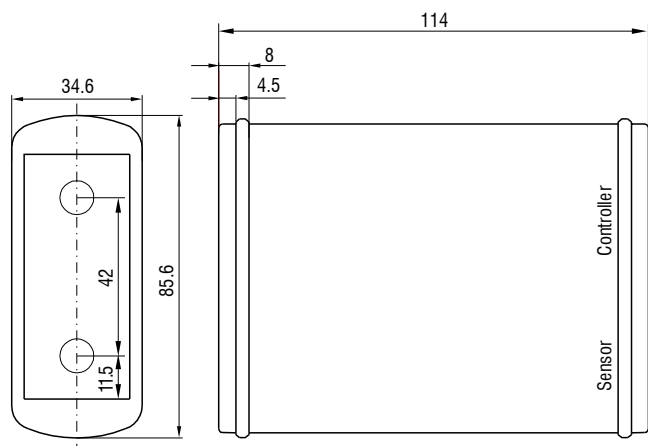

Mounting bracket for CP6001

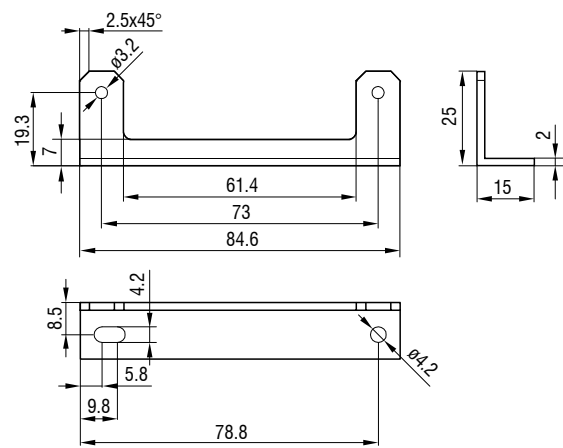

IF1032
Interface module

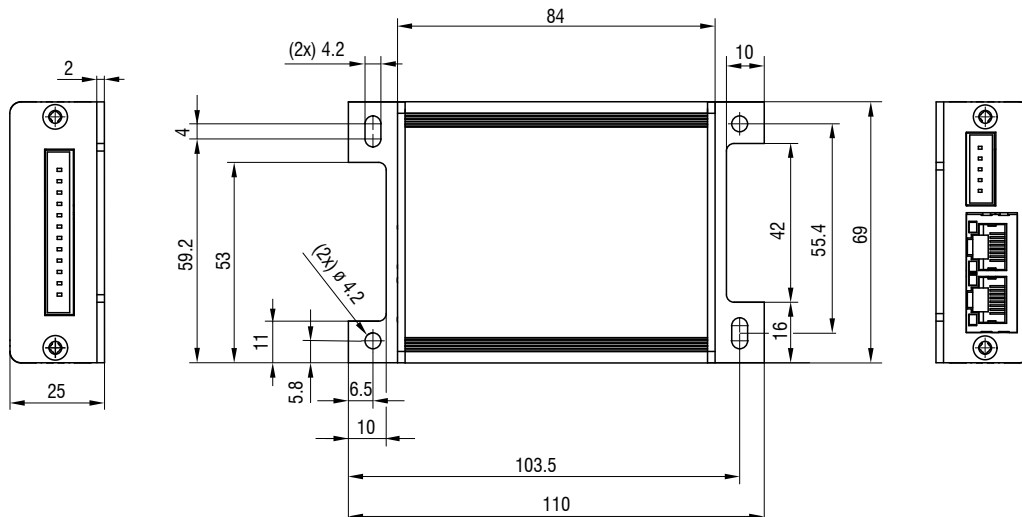

Sensors and Systems from Micro-Epsilon



Sensors and systems for displacement, distance and position



Sensors and measurement devices for non-contact temperature measurement



Measuring and inspection systems for metal strips, plastics and rubber



Optical micrometers and fiber optics, measuring and test amplifiers



Color recognition sensors, LED analyzers and inline color spectrometers

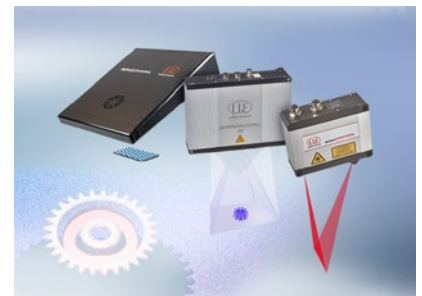

3D measurement technology for dimensional testing and surface inspection