

Sensor Mounting

The optoNCDT 5500 sensor is an optical system for measurements with micrometer accuracy. Ensure careful handling during installation and operation!

- Mount the sensor only to the existing through-bores (mounting holes) on a flat surface. Any type of clamping is not permitted.
- Mount the sensor using two M4 screws or the via the through-bores for M3 using the screws from the accessories.

Measuring Range, Start of Measuring Range

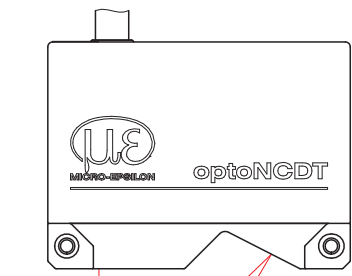

	Digital value
Ethernet	0x7FFFFFF5
e-SMR	depends on measuring range
SMR	Nanometer
MMR	Nanometer
EMR	Nanometer
e-EMR	depends on measuring range
	0x7FFFFFF6

e-SMR Start of extended measuring range
SMR Start of measuring range
MMR Mid of measuring range
EMR End of measuring range
e-EMR End of extended measuring range
e-MR Extended measuring range

The digital values apply to distance values without zeroing or mastering.

Mounting

Bolt connection

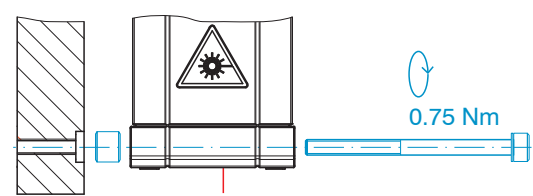

M3 x 40; ISO 4762, A2-70

Direct fastening

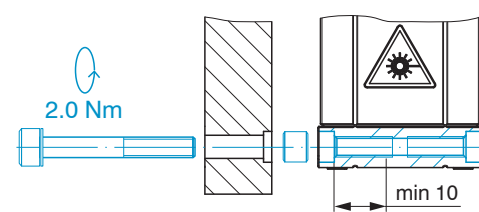

M4; ISO 4762, A2-70;
Screwing depth min. 10 mm

Drawings, Free Space

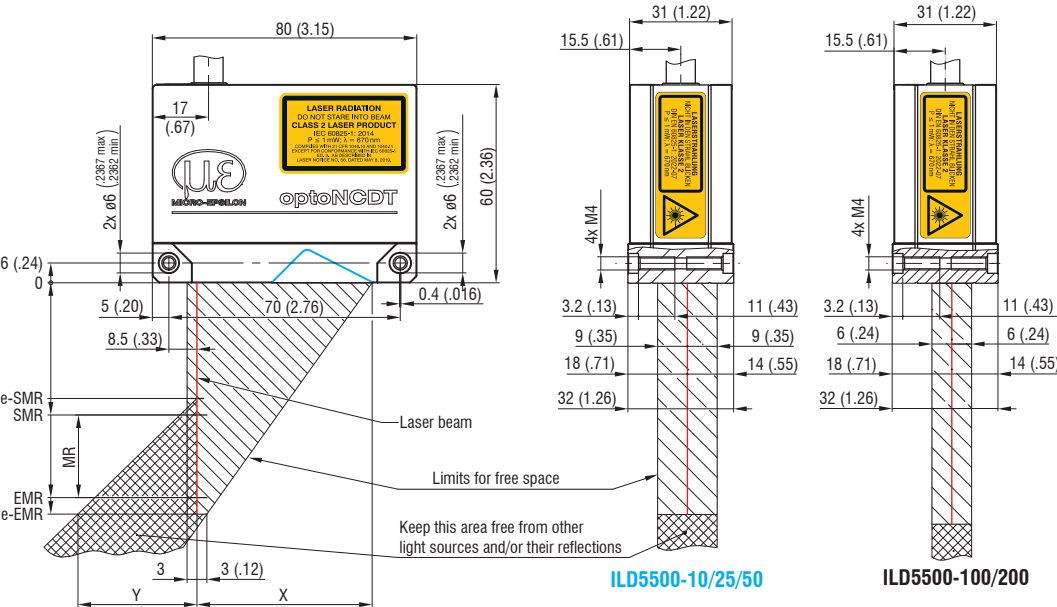

MB	10	25	50	100	200
e-SMR	27.5	35	40	55	70
SMR	30	40	45	70	100
MMR	35	52.5	70	120	200
EMR	40	65	95	170	300
e-EMR	42.5	72.5	115	205	370
X standard MR	49	52	51	58	59
X with e-MR	49	53	52	59	60
Y standard MR	17	32	51	64	92
Y with e-MR	26	51	81	106	167

Dimensions in mm

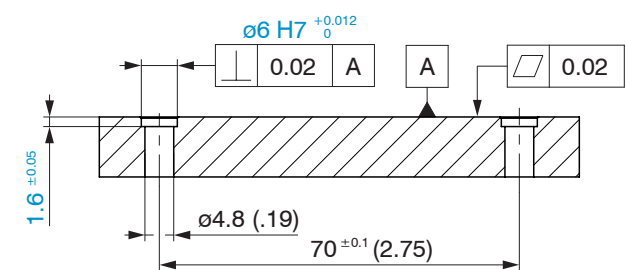

Dimensional drawing, drilling pattern, mounting plate

Alignment by centering elements (optional)

Connector and Sensor cable

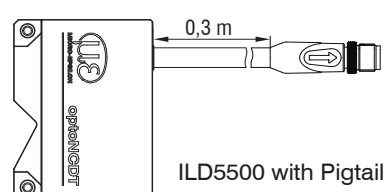

Pin assignment

Signal	Wire color	Comments
V ₊	Red	Power supply
GND	Blue	Reference ground
Laser on/off +	Black	Switching input
Laser on/off -	Violet	

12 ... 30 VDC, typ. 24 VDC

Open end connections, PC1900-IE-x/OE-RJ45

Signal	Pin	Comments
V ₊	1	Power supply
GND	2	Reference ground
Laser on/off +	7	Switching inputs
Laser on/off -	8	

Pigtail connections on the sensor, 12-pin connector, M12, pin side pigtail cable connector

Supply voltage

Nominal value: 24 V DC (12 ... 30 V, P < 3 W).

Industrial Ethernet with PoE

Sensor supply is via a PoE-capable switch. Phantom powering (PoE) is possible via the

- PC1900-IE-x/RJ45
- PC1900-IE-x/OE-RJ45

cables.

Industrial Ethernet without PoE

Sensor supply is via the PC1900-IE-x/OE-RJ45 cable.

12 ... 30 VDC	Sensor pin	PC1900-IE-x/OE-RJ45 Color	Power supply
1	1	Red	V ₊
2	2	Blue	GND

As an alternative to PoE, the sensor can be supplied with the optional PS2020 power supply unit. Voltage supply only for measuring devices, not to be used for drives or similar sources of impulse interference at the same time. MICRO-EPSILON recommends using an optional available power supply unit PS2020 for the sensor.

- Only turn on the power supply after wiring has been completed.
- Connect the inputs Pin 1 and Pin 2 at the sensor with a 24V power supply.

Laser Safety

The optoNCDT 5500 operates with a semiconductor laser with a wavelength of 670 nm (visible/red). The sensors fall within laser class 2. The laser is operated on a pulsed mode, the maximum optical power is ≤ 1 mW. The pulse frequency depends on the adjusted measuring rate.

- Observe the national laser protection regulations.

Although the laser output is low, directly looking into the laser beam must be avoided. Close your eyes or immediately turn away if the laser beam hits the eye.

Lasers of Class 2 are not subject to notification and a laser protection officer is not required.

The following warning labels must be attached to the cover (front and/or rear side) of the sensor housing. The laser warning labels for Germany have already been attached. For other non German speaking countries, an IEC standard label is included in delivery and the versions valid for the user's country must be attached before the device is put into operation for the first time.



CAUTION

Laser radiation. Irritation or injury of the eyes possible. Close your eyes or immediately turn away if the laser beam hits the eye.

Laser warning sign at the sensor housing

During operation of the sensor, the pertinent regulations according to IEC 60825-1 on „Safety of laser products“ must be fully observed at all times. The sensor complies with all applicable laws for the manufacturer of laser devices.

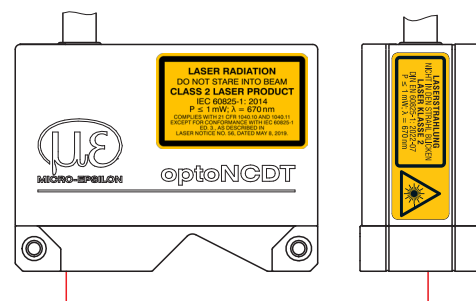

True reproduction of the sensors with its actual location of the warning labels, class 2

- If both warning labels are covered over when the unit is installed, the user must ensure that supplementary labels are applied.

Operation of the laser is indicated visually by the LED State on the sensor.

The housing of the optical sensors may only be opened by the manufacturer.

For repair and service purposes, the sensors must always be sent to the manufacturer.

Please observe national regulations, e. g., Laser Notice No. 56 for the USA.

Electrical Connections

RJ45 Connection, PoE, Laser On/Off via Software

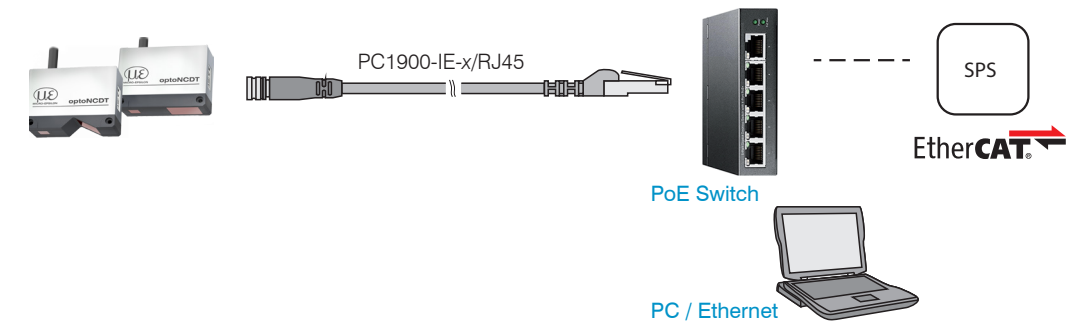

RJ45 Connection, PoE, Laser On/Off via Hardware

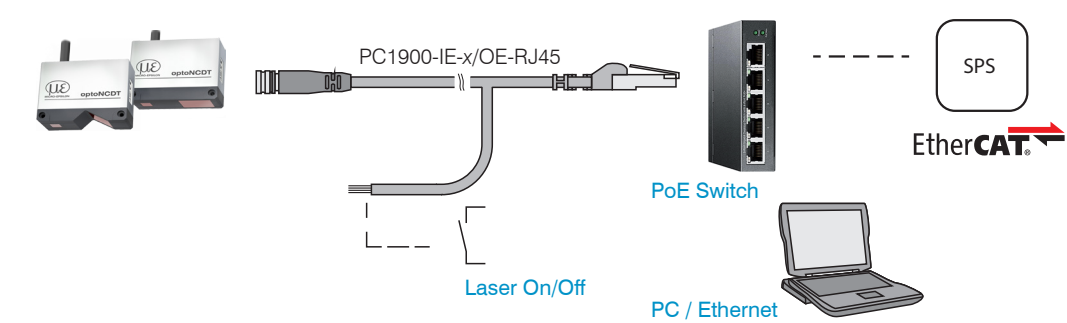

RJ45 Connection, Supply via Optional Power Supply Unit, Laser On/Off via Hardware

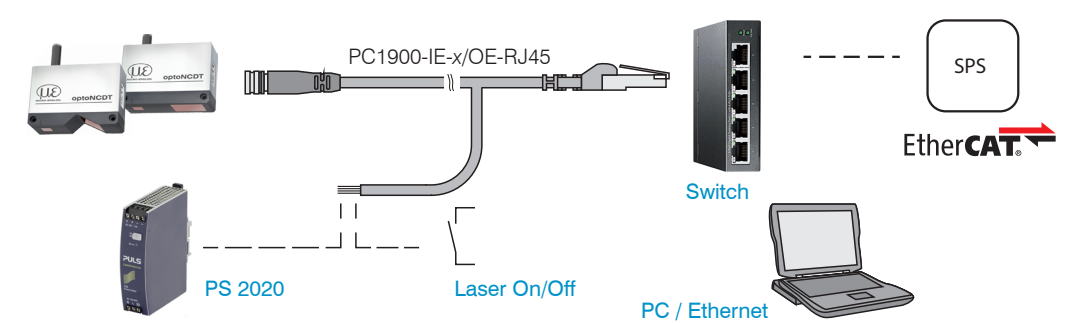

MICRO-EPSILON MESSTECHNIK GmbH & Co. KG
Koenigbacher Str. 15 • 94496 Ortenburg / Germany
Tel. +49 (0) 8542 / 168-0 • Fax +49 (0) 8542 / 168-90
info@micro-epsilon.com • www.micro-epsilon.com
Your local contact: www.micro-epsilon.com/contact/worldwide/



Operating Instructions optoNCDT 5500 EtherCAT

Intended Use

The optoNCDT 5500 is designed for use in industrial and laboratory applications. It is used for measuring displacement, distance and position as well as in quality control and dimensional testing.

The sensor must only be operated within the limits specified in the technical data, see operating instructions, Chap 3.3. The sensor must be used in such a way that no persons are endangered or machines and other material goods are damaged in the event of malfunction or total failure of the sensor. Take additional precautions for safety and damage prevention in case of safety-related applications.

Warnings

Avoid unnecessary laser radiation to be exposed to the human body.

- Switch off the sensor for cleaning and maintenance.
- Switch off the sensor for system maintenance and repair if the sensor is integrated into a system.

Caution - use of controls or adjustments or performance of procedures other than those specified may cause harm.

Connect the power supply according to the safety regulations for electrical equipment. The supply voltage must not exceed the specified limits.

> Risk of injury, damage to or destruction of the sensor.

Avoid constant exposure of the sensor to splashes of water. Avoid exposure of sensor to aggressive media (detergents, cooling emulsions).

> Damage to or destruction of the sensor

Avoid shock and vibration to the sensor. Protect the sensor cable against damage.

> Damage to or destruction of the sensor, failure of the measuring device.

Control and Display Elements

State LED	Meaning
Green	Measuring object within the measuring range
Green shiny	The object being measured is in the extended measuring range; outside the standard measuring range.
Yellow	Measuring object in the mid of the measuring range
Red	No distance value available, e.g. target outside the measuring range, too low reflection
Off	Laser switched off
LED RUN/SF	Meaning
	depending on EtherCAT operation
LED ERR/BF	Meaning
	depending on EtherCAT operation
Select button	Meaning
	- Switching operating mode - Resetting to factory setting

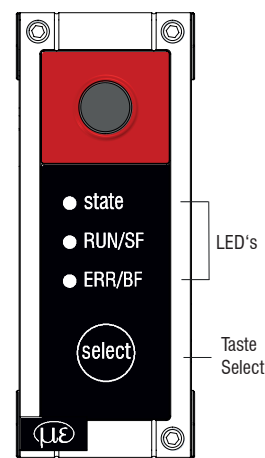

Quick Guide

Structure of the Components

➤ Mount the sensor and connect the components to one another.

Initial Operation

➤ Connect the sensor to a power supply if PoE is not used.

Operation via Web Interface

The sensors start with the last stored operating mode. Standard is Industrial Ethernet (IE). A web server is implemented in the sensor; the web interface displays, among other things, the current settings of the sensor. Operation is only possible while there is an Ethernet connection to the sensor.

EtherCAT	
Ethernet setup mode	Ethernet over EtherCAT (EoE)
➤ Switch to the Ethernet setup mode.	Parallel to the EtherCAT operation you can adjust the sensor.
Details can be found in section <i>Switch between Industrial Ethernet Operation and Ethernet Setup Mode</i> .	➤ Enable the EoE in your PLC software.
The standard IP address is 169.254.168.150.	Virtual Ethernet Port is a name in Twin-CAT®.
Note: As IP setting of the network card to which the sensor is connected, we recommend a static configuration with 169.254.168.1 as IP address and the subnet mask 255.255.0.0.	➤ Assign a MAC address and an IP address to the slave.

Turning on the Laser

The measuring laser on the sensor is switched on via a software command or a switching input. This allows to switch off the sensor for maintenance purposes or similar. Response time: after the laser is switched on, the sensor needs depending on the measuring rate five cycles to send correct measured data.

Laser on/off via software, Supply with PoE	Laser on/off via hardware, Supply with PoE	Laser on/off via hardware, Supply without PoE
The measuring laser on the sensor is activated via a software command.	The measuring laser on the sensor is activated via a switch or similar.	A switching transistor with open collector (for example in an optocoupler), a relay contact or a digital TTL or HTL signal are suitable for switching.
Activation using the PC1900-IE-x/OE-RJ45 cable is possible.	Activation using the PC1900-IE-x/OE-RJ45 cable is possible.	
	No external resistance is required for current limitation. For permanent "Laser on", connect the black and violet wires.	The inputs are not electrically separated. 24 V logic (HTL): Low level ≤ 3 V; High level ≥ 8 V (max 30 V) internal pull-up resistor, an open input is detected as High. Max. switching frequency 10 Hz The ground of the logic circuit must be galvanically connected to "Laser on/off -".

Switch between EtherCAT Operation and Ethernet Setup Mode

The sensor starts in the last stored operating mode. It is factory set to EtherCAT. Access via Ethernet is possible in the Ethernet setup mode.

➤ Press and hold the **Select** button on the sensor before switching on the power supply on the sensor. Release the button again as soon as the **State LED** flashes yellow. Press the button again for approx. 10 to 15 seconds until the **State LED** flashes red.

Within the time $t_2 \dots t_3$ the red flashing with 8 Hz starts after 10 seconds. The key must be released again after 15 seconds at the latest. When the **Select** key is released at the latest at time t_3 , the **State LED** starts to flash yellow at 8 Hz.

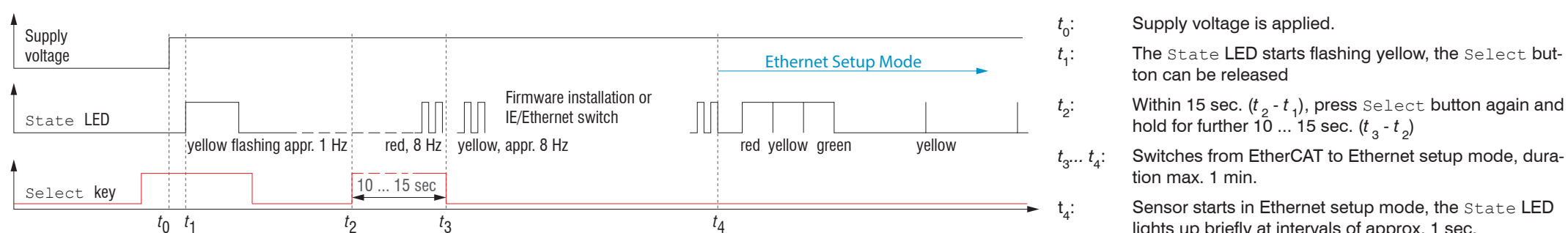

Flowchart for starting a sensor in Ethernet setup mode

After completion of the firmware installation/switch, the sensor reboots at time t_4 .

Switch between Ethernet Setup Mode and EtherCAT

The sensor starts in the last stored operating mode. With the **select** button, you can set the sensor to the EtherCAT mode.

➤ Press and hold the **Select** button on the sensor before switching on the power supply on the sensor. Release the button again as soon as the **State LED** flashes yellow. Press the button again for approx. 10 to 15 seconds until the **State LED** flashes red.

Within the time $t_2 \dots t_3$ the red flashing with 8 Hz starts after 10 seconds. The key must be released again after 15 seconds at the latest. When the **Select** key is released at the latest at time t_3 , the **State LED** starts to flash yellow at 8 Hz.

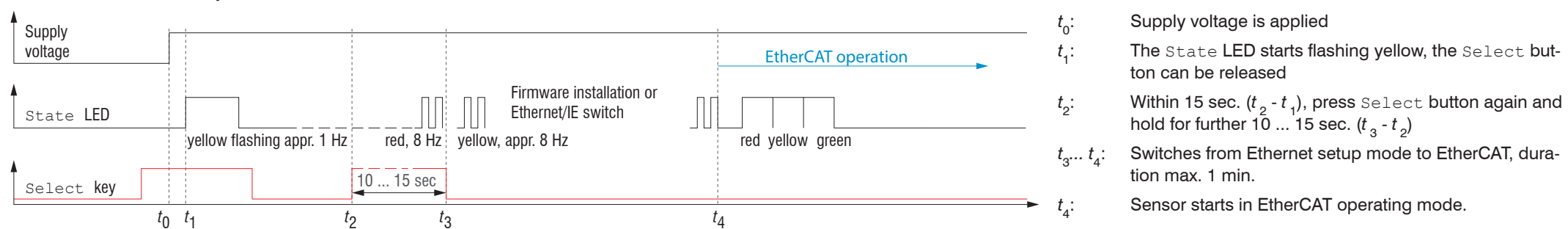

Flowchart for starting a sensor in EtherCAT operation

After completion of the firmware installation/switch, the sensor reboots at time t_4 .

Proper Environment

- Protection class: IP67 (applies only when sensor cable is plugged in)
Lenses are excluded from the protection class. Contamination of the lenses causes impairment or failure of the function.

- Temperature range
▪ Operation: 0 ... +45 °C
▪ Storage: -20 ... +70 °C

- Humidity: 5 ... 95 % (non-condensing)
- Ambient pressure: Atmospheric pressure

Access via Web Interface

➤ Start your web browser.

➤ Type the IP address of the sensor into the address bar.

Interactive web pages you can use to configure the sensor are now displayed in the web browser. The web interface does not guarantee real-time measurements. The currently running measurement can be controlled using the function buttons in the **Chart type** section.

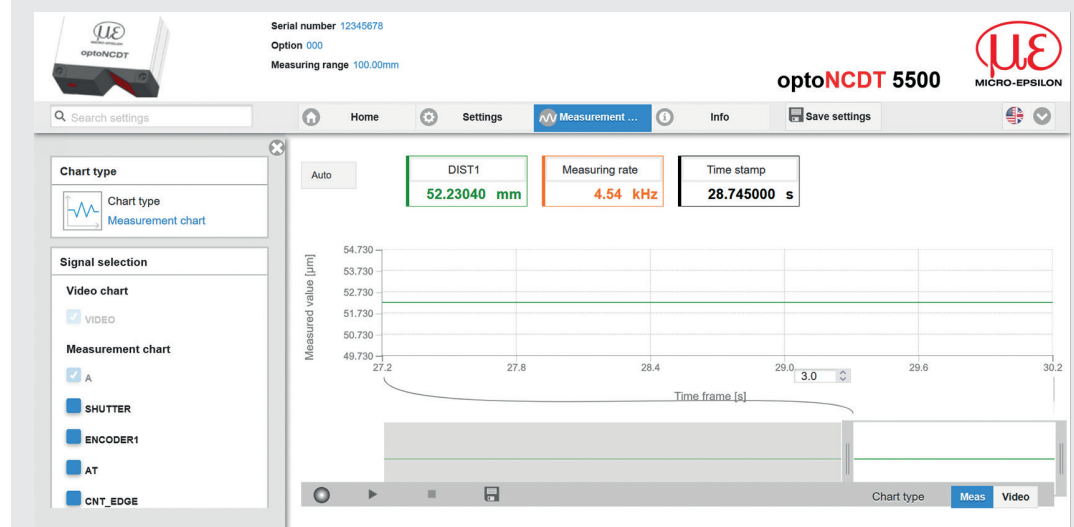

In the top navigation bar, other functions (settings, measurement chart etc.) are available. The appearance of the websites can change dependent of the functions. Each page contains dynamic parameter descriptions and tips on completing the web page.

After parameterization, store all settings permanently in a parameter set so that they are available again the next time the sensor is switched on. To do this, use the **Save settings** button.

Positioning the Target

➤ Position the target as centrally as possible within the measuring range.

The **state LED** on the sensor indicates the position of the target to the sensor.

LED	Color	Meaning
state	Off	Laser beam is switched off.
	Green	Measuring object within the measuring range
	Yellow	Target is in the mid of measuring range.
	Red	No distance value available, e.g. target outside the measuring range, too low reflection

Saving the Settings, Continuing Industrial Ethernet Operation

➤ Go to **Settings > System settings > Load & Save** or click the **Save settings** button.

The sensor now also saves the settings for use in Industrial Ethernet operation.

For sensors with operation mode EtherCAT:

➤ Go to **Settings > System settings > Boot mode**. Select the entry **Industrial Ethernet**.

The sensor disconnects from the browser and boots automatically with the Industrial Ethernet firmware. The boot process can take up to one minute.

Alternatively, you can return to the Industrial Ethernet operation via the **select** button. Details can be found in section *Switch between Ethernet Setup Mode and EtherCAT*.

Continue working in your PLC environment.

You can find more information about the sensor in the operating instructions. They are available online at:

<https://www.micro-epsilon.com/distance-sensors/laser-sensors/optoncdt-5500/>
or with the QR code at right:

