

## Sensor Mounting

The optoNCDT 1900 sensor is an optical system for measurements with micrometer accuracy. Ensure careful handling during installation and operation!

- Mount the sensor only to the existing through-bores (mounting holes) on a flat surface. Any type of clamping is not permitted.
- Mount the sensor using two M4 screws or the via the through-bores for M3 using the screws from the accessories.

## Measuring Range, Start of Measuring Range

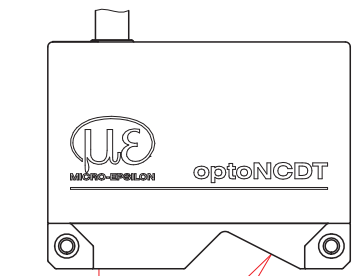

	Digital value
	Ethernet
	0x7FFFFFF5
e-SMR	depends on measuring range
SMR	Nanometer
MMR	Nanometer
EMR	Nanometer
e-EMR	depends on measuring range
	0x7FFFFFF6

e-SMR Start of extended measuring range      EMR End of measuring range  
 SMR Start of measuring range                  e-EMR End of extended measuring range  
 MMR Mid of measuring range                  e-MR Extended measuring range

The digital values apply to distance values without zeroing or mastering.

## Mounting

### Bolt connection

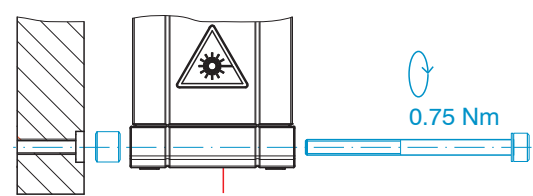

M3 x 40; ISO 4762, A2-70

### Direct fastening

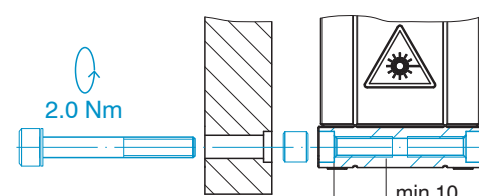

M4; ISO 4762, A2-70;  
Screwing depth min. 10 mm

## Drawings, Free Space

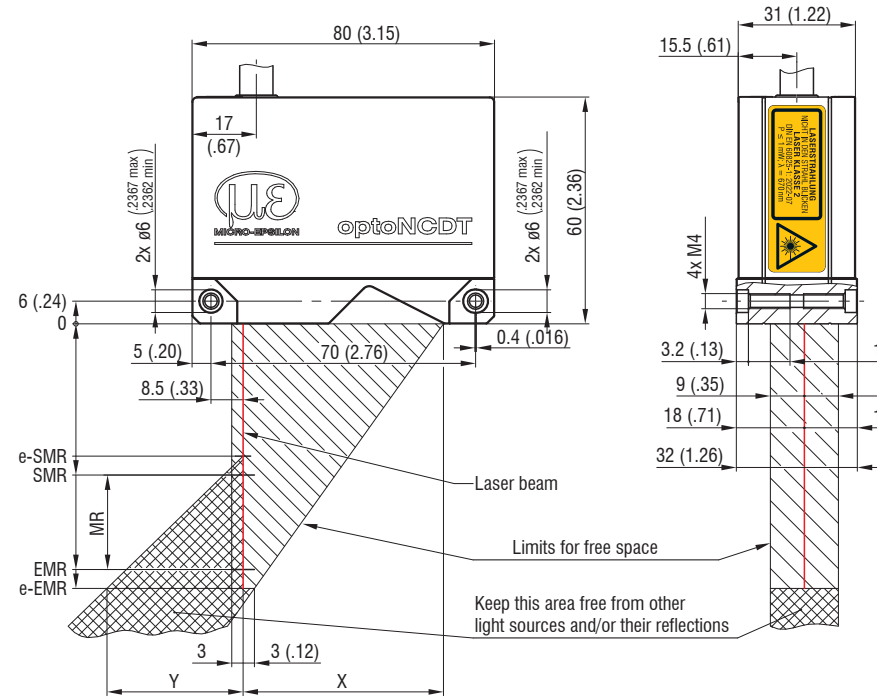

Dimensional drawing ILD5500-10/25/50 dimensions in mm (inches)

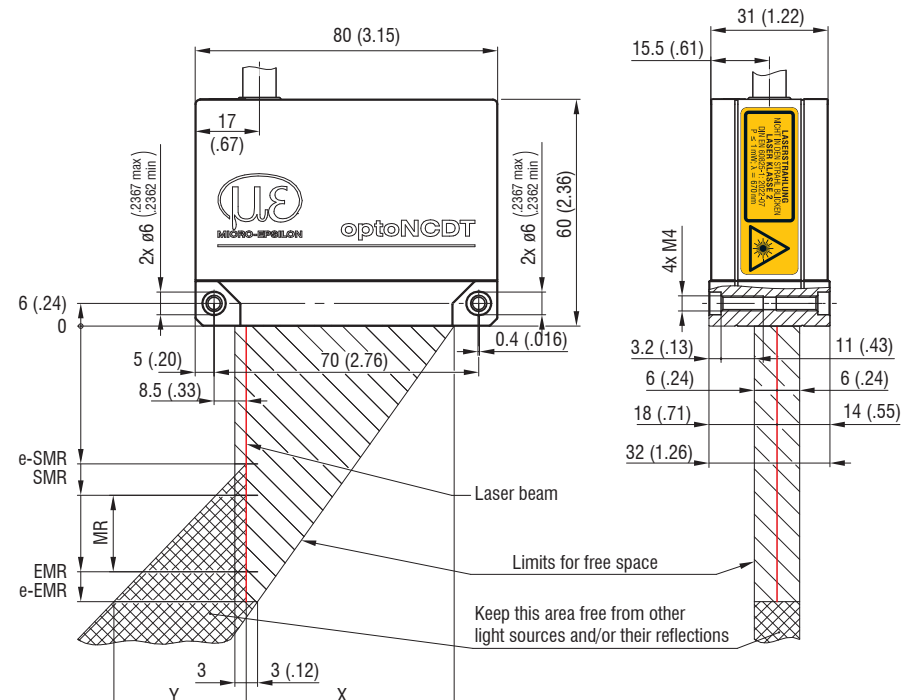

Dimensional drawing ILD5500-100/200, dimensions in mm (inches)

MB	10	25	50	100	200
e-SMR	27.5	35	40	55	70
SMR	30	40	45	70	100
MMR	35	52.5	70	120	200
EMR	40	65	95	170	300
e-EMR	42.5	72.5	115	205	370
X standard MR	49	52	51	58	59
X with e-MR	49	53	52	59	60
Y standard MR	17	32	51	64	92
Y with e-MR	26	51	81	106	167

Dimensions in mm

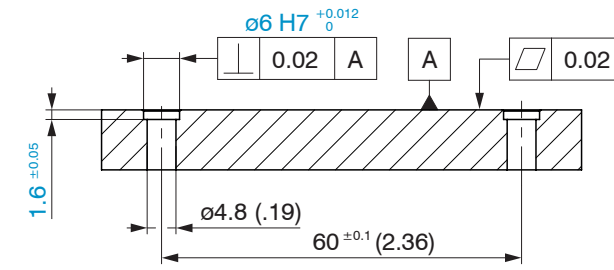

Dimensional drawing, drilling pattern, mounting plate

Alignment by centering elements (optional)

## Connector and Sensor cable

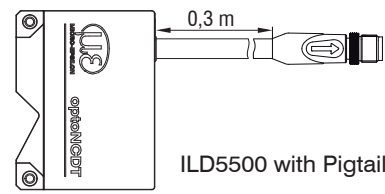

## Pin assignment

Signal	Wire color	PC1900-IE-x/OE-RJ45	Comments
V <sub>+</sub>	Red		Power supply
GND	Blue		Reference ground
Laser on/off +	Black		Switching input
Laser on/off -	Violet		

Open end connections, PC1900-IE-x/OE-RJ45

Signal	Pin	Comments
V <sub>+</sub>	1	Power supply
GND	2	Reference ground
Laser on/off +	7	Switching inputs
Laser on/off -	8	

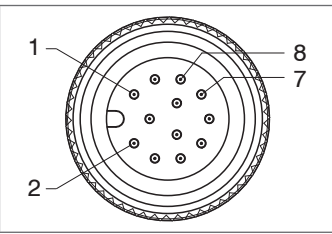

Pigtail connections on the sensor, 12-pin connector, M12, pin side pigtail cable connector

## Laser Safety

The optoNCDT 5500 operates with a semiconductor laser with a wavelength of 670 nm (visible/red) or 658 nm (visible/red). Operation of the laser is indicated visually by the LED state on the sensor. During operation of the sensor, the pertinent regulations according to IEC 60825-1 on „Safety of laser products“ must be fully observed at all times. The sensor complies with all applicable laws for the manufacturer of laser devices. Please observe national regulations, e. g., Laser Notice No. 56 for the USA.

If both warning labels are covered over when the unit is installed, the user must ensure that supplementary labels are applied. Observe the national laser protection regulations.

## Laser Class 2

The sensors fall within laser class 2. The laser is operated on a pulsed mode, the maximum optical power is ≤ 1 mW. The pulse frequency depends on the adjusted measuring rate (0.25 ... 10 kHz). The pulse duration of the peaks is regulated depending on the measuring rate and reflectivity of the target and can be 4 up to 3995 μs.



Laser warning sign on the sensor housing

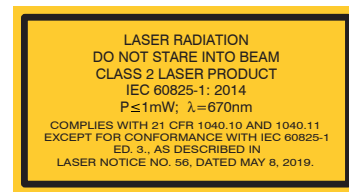

Laser labels on the sensor cable



Laser radiation. Irritation or injury of the eyes possible. Close your eyes or immediately turn away if the laser beam hits the eye.

## Laser Class 3R

The sensors fall within laser class 3R. The laser is operated on a pulsed mode, the maximum optical power is ≤ 5 mW. The pulse frequency depends on the adjusted measuring rate (0.25 ... 10 kHz). The pulse duration of the peaks is regulated depending on the measuring rate and reflectivity of the target and can be 4 up to 3995 μs.



Laser warning sign on the sensor housing

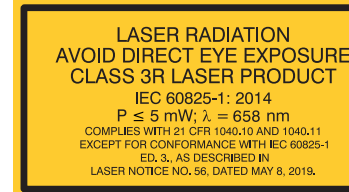

Laser labels on the sensor cable



Laser radiation. Irritation or injury of the eyes possible. Use suitable protective equipment and close your eyes or immediately turn away if the laser beam hits the eye.

Accordingly, the following applies: The accessible laser radiation is harmful to the eyes. Looking directly into the laser beam is harmful to the eyes with laser class 3R devices. Reflections of shiny or mirroring surfaces are also harmful to the eyes.

Class 3R laser sensors require a laser protection officer. Mark the laser area recognizable and everlasting. During operation the laser area has to be restricted and marked.

## Supply voltage

Nominal value: 24 V DC (11 ... 30 V, P < 3 W).

Sensor supply is via the PC1900-IE-x/OE-RJ45 cable.

11 ... 30 VDC	Sensor pin	PC1900-IE-x/OE-RJ45 Color	Power supply
1	1	Red	V <sub>+</sub>
2	2	Blue	GND

Voltage supply only for measuring devices, not to be used for drives or similar sources of impulse interference at the same time. MICRO-EPSILON recommends using an optional available power supply unit PS2020 for the sensor.

- Only turn on the power supply after wiring has been completed.
- Connect the inputs Pin 1 and Pin 2 at the sensor with a 24V power supply.

## Electrical Connections

### RJ45 Connection, Supply via Optional Power Supply Unit, Laser On/Off via Hardware

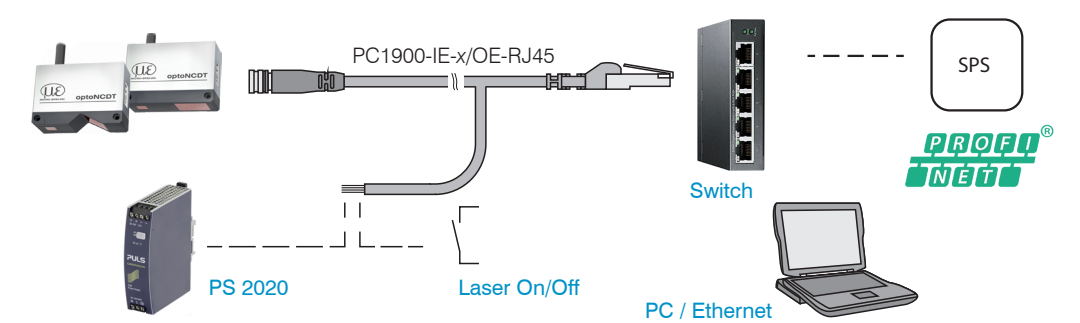

MICRO-EPSILON MESSTECHNIK GmbH & Co. KG  
 Koenigbacher Str. 15 • 94496 Ortenburg / Germany  
 Tel. +49 (0) 8542 / 168-0 • Fax +49 (0) 8542 / 168-90  
 info@micro-epsilon.com • www.micro-epsilon.com

Your local contact: [www.micro-epsilon.com/contact/worldwide/](http://www.micro-epsilon.com/contact/worldwide/)

CE UK CA  
 X9771508.01-A012026PBS



Operating Instructions  
 optoNCDT 5500  
 PROFINET

## Intended Use

The optoNCDT 5500 is designed for use in industrial and laboratory applications. It is used for measuring displacement, distance and position as well as in quality control and dimensional testing.

The sensor must only be operated within the limits specified in the technical data, see operating instructions, Chap 3.3. The sensor must be used in such a way that no persons are endangered or machines and other material goods are damaged in the event of malfunction or total failure of the sensor. Take additional precautions for safety and damage prevention in case of safety-related applications.

## Warnings

Avoid unnecessary laser radiation to be exposed to the human body.

- Switch off the sensor for cleaning and maintenance.
- Switch off the sensor for system maintenance and repair if the sensor is integrated into a system.

Caution - use of controls or adjustments or performance of procedures other than those specified may cause harm.

Connect the power supply according to the safety regulations for electrical equipment. The supply voltage must not exceed the specified limits.  
 > Risk of injury, damage to or destruction of the sensor.

Avoid constant exposure of the sensor to splashes of water. Avoid exposure of sensor to aggressive media (detergents, cooling emulsions).  
 > Damage to or destruction of the sensor

Avoid shock and vibration to the sensor. Protect the sensor cable against damage.  
 > Damage to or destruction of the sensor, failure of the measuring device.

## Control and Display Elements

State LED	Meaning
Green	Measuring object within the measuring range
Green shiny	The object being measured is in the extended measuring range; outside the standard measuring range.
Yellow	Measuring object in the mid of the measuring range
Red	No distance value available, e.g. target outside the measuring range, too low reflection
Off	Laser switched off
LED RUN/SF/MS	Meaning
	depending on PROFINET operation
LED ERR/BF/NS	Meaning
	depending on PROFINET operation
Select button	Meaning
	- Resetting to factory setting

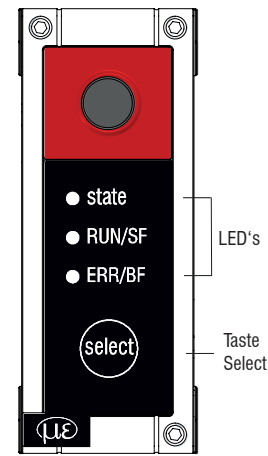

## Turning on the Laser

The measuring laser on the sensor is switched on via a software command or a switching input. This allows to switch off the sensor for maintenance purposes or similar. Response time: after the laser is switched on, the sensor needs depending on the measuring rate five cycles to send correct measured data.

### Laser on/off via hardware, Supply

A switching transistor with open collector (for example in an optocoupler), a relay contact or a digital TTL or HTL signal are suitable for switching.

Activation using the PC1900-IE-x/OE-RJ45 cable is possible.

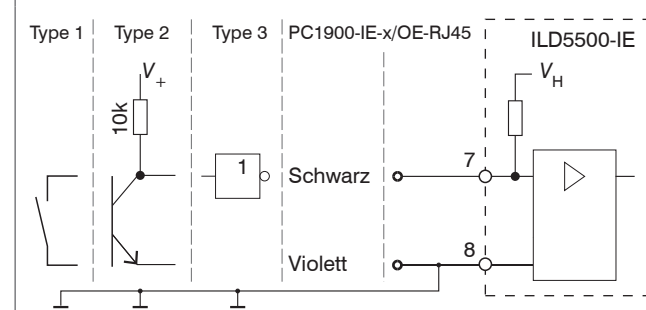

The inputs are not electrically separated.

24 V logic (HTL): Low level  $\leq 3$  V;  
High level  $\geq 8$  V (max 30 V)

internal pull-up resistor, an open input is detected as High.  
Max. switching frequency 10 Hz

The ground of the logic circuit must be galvanically connected to "Laser on/off -".

No external resistance is required for current limitation. For permanent "Laser on", connect the black and violet wires.

## Proper Environment

- Protection class: IP67 (applies only when sensor cable is plugged in)

Lenses are excluded from the protection class. Contamination of the lenses causes impairment or failure of the function.

- Temperature range

▪ Operation: 0 ... +50 °C

▪ Storage: -20 ... +70 °C

- Humidity:

5 ... 95 % (non-condensing)

- Ambient pressure: Atmospheric pressure

## Quick Guide

### Structure of the Components

➤ Mount the sensor and connect the components to one another.

### Initial Operation

➤ Connect the sensor to a power supply.

### Operation via Web Interface

The sensors start with the last stored operating mode. Standard is Industrial Ethernet (IE). A web server is implemented in the sensor; the web interface displays, among other things, the current settings of the sensor. Operation is only possible while there is an Ethernet connection to the sensor.

#### PROFINET

**i** The optoNCDT 5500 with PROFINET has no IP address by default. The static IP address and the device name are assigned via DCP (Discovery and Configuration Protocol). The IP address and the device name can be assigned, e.g., via the TIA Portal software.

➤ Assign an IP address to the sensor.

You can find an example of this in the appendix of the operating instructions.

## Access via Web Interface

➤ Start your web browser.

➤ Type the IP address of the sensor into the address bar.

Interactive web pages you can use to configure the sensor are now displayed in the web browser. The web interface does not guarantee real-time measurements. The currently running measurement can be controlled using the function buttons in the **Chart type** section.

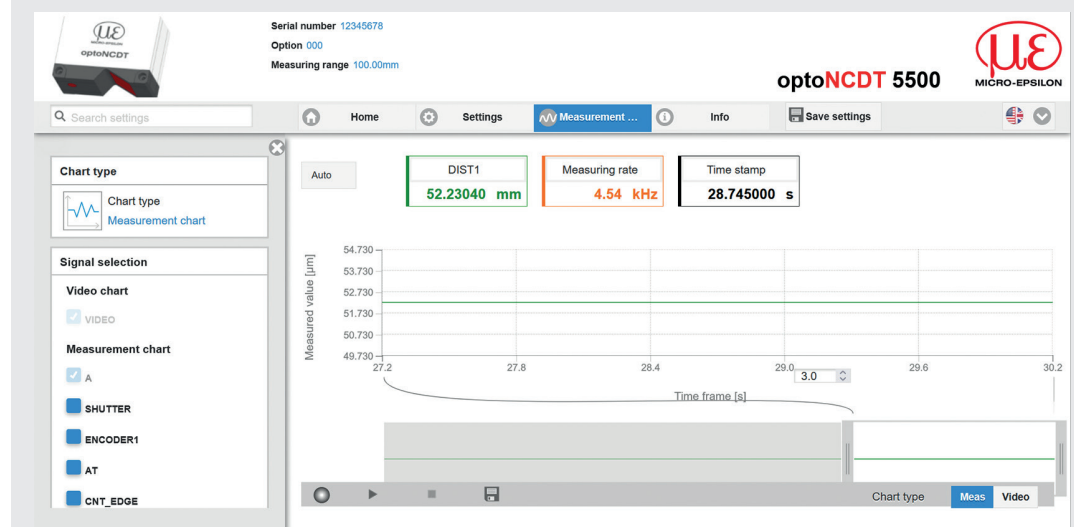

In the top navigation bar, other functions (settings, measurement chart etc.) are available. The appearance of the websites can change dependent of the functions. Each page contains dynamic parameter descriptions and tips on completing the web page.

After parameterization, store all settings permanently in a parameter set so that they are available again the next time the sensor is switched on. To do this, use the **Save settings** button.

## Positioning the Target

➤ Position the target as centrally as possible within the measuring range.

The **state** LED on the sensor indicates the position of the target to the sensor.

LED	Color	Meaning
state	Off	Laser beam is switched off.
	Green	Measuring object within the measuring range
	Yellow	Target is in the mid of measuring range.
	Red	No distance value available, e.g. target outside the measuring range, too low reflection

## Saving the Settings, Continuing Industrial Ethernet Operation

➤ Go to **Settings > System settings > Load & Save** or click the **Save settings** button.

The sensor now also saves the settings for use in Industrial Ethernet operation.

Continue working in your PLC environment.

You can find more information about the sensor in the operating instructions. They are available online at:

<https://www.micro-epsilon.com/distance-sensors/laser-sensors/optoncdt-5500/>

or with the QR code at right:

